

Application Note No. 9260-001
Power and Signal Line Interruptions
for Automotive Tests

Electronic Switch TOE 9260

9260E-AN001_Rev00.doc

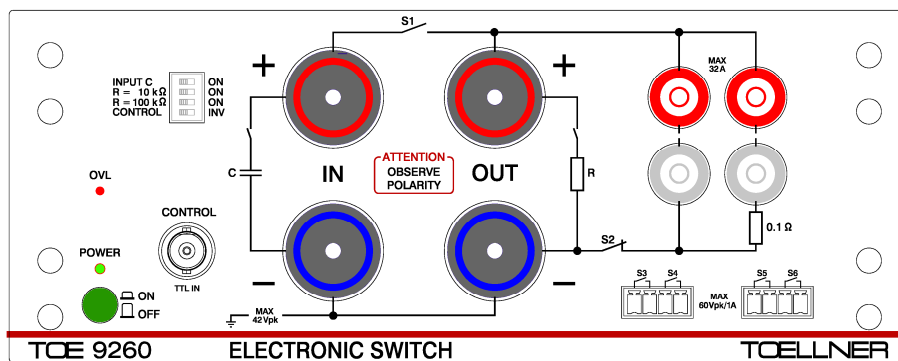

TOELLNER®

TOELLNER ELECTRONIC INSTRUMENTE GMBH
Gahlenfeldstrasse 31, 58313 Herdecke, Germany
☎ +49 (0) 23 30 - 97 91 91 • Fax +49 (0) 23 30 - 97 91 97
E-Mail: info@toellner.de • Web: www.toellner.de

Subject to technical changes

Contents

Page

1.	Introduction.....	3
1.1	Required test equipment	3
2.	Tests according to standard LV 124.....	5
2.1	LV 124, E-10, Short interruptions	5
2.2	E-10, Short interruptions – reference measurements.....	6
2.3	LV 124, Test E-13, Pin interruption	6
2.3.1	E-13, interruption of signal pins	6
2.3.2	E-13, interruption of signal pins – reference measurements.....	7
2.3.3	E-13, interruption of ground pins	8
2.3.4	E-13, interruption of ground pins – reference measurements.....	8
3.	Tests according to standard LV 148.....	10
3.1	LV 148, E48-09, Short interruptions	10

1. Introduction

The Electronic Switch **TOE 9260** is a device for time-based turning on and off of load and signal currents. This device provides an electronic, unidirectional power switch as well as four electronic bidirectional signal line switches. The power switch incorporates a selectable load-parallel crossover for selective discharging of buffered loads.

A digital input signal can be used to generate on- and off-durations of any time down to the microsecond range for both the power switch and the signal line switches.

By these features, the TOE 9260 especially is applicable for the following tests according to the automotive standards LV 124 and LV 148:

- LV 124, E-10: Short interruptions
- LV 124, E-13: Pin interruption
- LV 148, E48-09: Short interruptions

There are many other industry standards based on LV 124 and LV 148 like VW 80000, GS 95024-2, VW 82148, etc. with power and signal line interruptions, where the Electronic Switch TOE 9260 can be applied.

Subject of this document is how these tests are carried out by use of the TOE 9260, especially under consideration of the following points:

- Test assembly and wiring of the components
- Choice of the right switch, i.e. power switch resp. signal line switch of the TOE 9260
- Reference measurements according to the requirements of the LV 124-2013

1.1 Required test equipment

Commonly the following components are needed for the test assemblies:

- DUT (Device under Test)
- Power supply according to the requirements of the Device under Test
- Electronic Switch TOE 9260
- 4x high current cable (cross section 16 mm²) with connector KBT6AR-N/16-S (Manufacturer: Multi-Contact) to connect the power supply and the DUT to the power switch of the TOE 9260.

Note Please note, that the connector KBT6AR-N/16-S can only be mounted to a cable by use of special tooling, soldering is not possible.

The use of the following connection cables of length 1,20 m or 0,50 m TOE 9260/22 (Red) and TOE 9260/23 (Blue) is recommended:

Item No.	Item name
TOE 9260/22	0.50 m connection cable with 1 safety socket, red
TOE 9260/23	0.50 m connection cable with 1 safety socket, blue
TOE 9260/24	1.20 m connection cable with 1 safety socket, red
TOE 9260/25	1.20 m connection cable with 1 safety socket, blue

- Pulse source, e.g. Arbitrary Function Generator TOE 7761, or a DAQ-card with digital outputs
- PC as control device for the function generator or DAQ-card to generate the pulse sequences especially for the tests LV 124 E-10 resp. LV 148 E48-09
- Oscilloscope or fast data logger for evaluation of the measurement results

When performing tests according to LV 124-2013, additionally:

- Reference resistors 1 Ω , 100 Ω , and 1 k Ω of low inductance, $\pm 5\%$ tolerance to perform reference measurements. The use of the following reference resistor kits is recommended:

Item No.	Item name
TOE 9260/100	Reference Resistor Kit 1 Ω , 100 Ω , and 1 k Ω for power switch
TOE 9260/104	Reference Resistor 1 Ω / 1 k Ω for signal line switches

2. Tests according to standard LV 124

2.1 LV 124, E-10, Short interruptions

Test E-10 shall be applied to power supply lines of the DUT.

The test assembly for the test E-10 is shown in Fig. 1. With the connecting plug placed as shown, the assembly is configured for test case 2. For test case 1 the connecting plug has to be removed or placed in a neutral position, i.e. socket pair red – red or gray – gray.

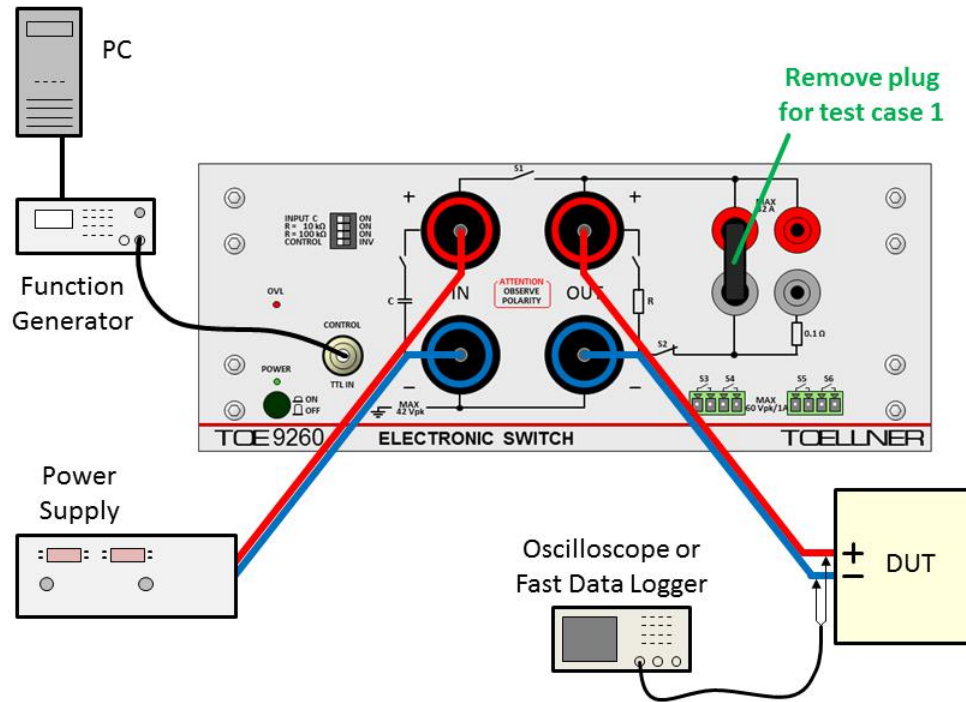

Fig. 1: Test assembly for LV 124, E-10

Note The important points for test execution in line with the requirements of the standard aim at the wiring as explained in the following:

- The cross section of the cables must fit to the drawn current. For currents up to 100 A please use the cables TOE 9260/22 and TOE 9260/23 (length 0.50 m) resp. TOE 9260/24 and TOE 9260/25 (length 1.20 m).
- The two wires from the power supply to the IN sockets of the TOE 9260 have to be laid as closely spaced as possible (e.g. twisted) to reach minimum inductance values.
- As long as no artificial network is applied between the power supply and the IN sockets of the TOE 9260, the internal capacitor at the input of the TOE 9260 should be activated by setting the DIP switch "INPUT C" to "ON". So the shortest possible rise and fall times of the voltage at the DUT are achieved.
- If an artificial network between the power supply and the IN sockets of the TOE 9260 is necessary, the internal capacitor at the input of the TOE 9260 must be deactivated by setting the DIP switch "INPUT C" to "OFF". In that case the two wires from the artificial network to the IN sockets of the TOE 9260 have to be laid as closely spaced as possible (e.g. twisted) and also kept as short as possible to get short rise and fall times at the DUT.
- Also the two wires from the OUT sockets of the TOE 9260 to the DUT have to be laid as closely spaced as possible (e.g. twisted). Any additional cable inductance will act as an inductive filter together with the resistance and / or capacitance of the DUT, which results in increased rise and fall times measured at the DUT.
- If the DUT has to be connected by a wiring harness or if a wiring harness is part of the DUT, the said remarks are valid for the cables from the OUT sockets of the TOE 9260 to the start point of the wiring harness.

2.2 E-10, Short interruptions – reference measurements

This section applies to LV 124, version 2013 only. That standard requires reference measurements before an interruption test is carried out with the DUT. Such a reference measurement gives proof of the slew rate of the switching operation. For the reference measurements of the E-10 test the DUT is replaced by a reference resistor of 1 Ω ± 5 % resp. 100 Ω ± 5 % of low parasitic inductance (→ Fig. 1).

To avoid the addition of cable inductivity, the reference resistor shall be connected as close to the output sockets of the TOE 9260 as possible. The reference resistors of the TOE 9260/100 kit may be connected directly to the output sockets without use of cables.

Because of the high power loss in case of the 1 Ω resistor operated at 11 V according to the LV 124, the test setup should be prepared in the powerless state. Test execution should be kept as short as possible.

2.3 LV 124, Test E-13, Pin interruption

The test E-13 has to be applied to signal pins as well as to ground pins. For both situations, the test assemblies are explained in the following.

2.3.1 E-13, interruption of signal pins

For the interruption of a signal pin, a signal line switch of the TOE 9260 is used. Such a signal line switch is applicable for a pin current up to 1 A.

If up to 2 A have to be switched, two signal line switches can be paralleled. It is not recommended to operate more than two switches in parallel. With three or four switches in parallel the timing requirements of the LV 124-2013 cannot be fulfilled with a 1 kΩ reference resistor. (For applications different from the LV 124 / LV 148 standards, there are four signal line switches available in the TOE 9260; if e.g. differential pairs or a 4-pole connection shall be switched at once.)

Fig. 2 shows the test assembly with use of one of the signal line switches of the TOE 9260. Only one pin has to be interrupted at one time. The test is then sequentially carried out for every signal pin of the DUT.

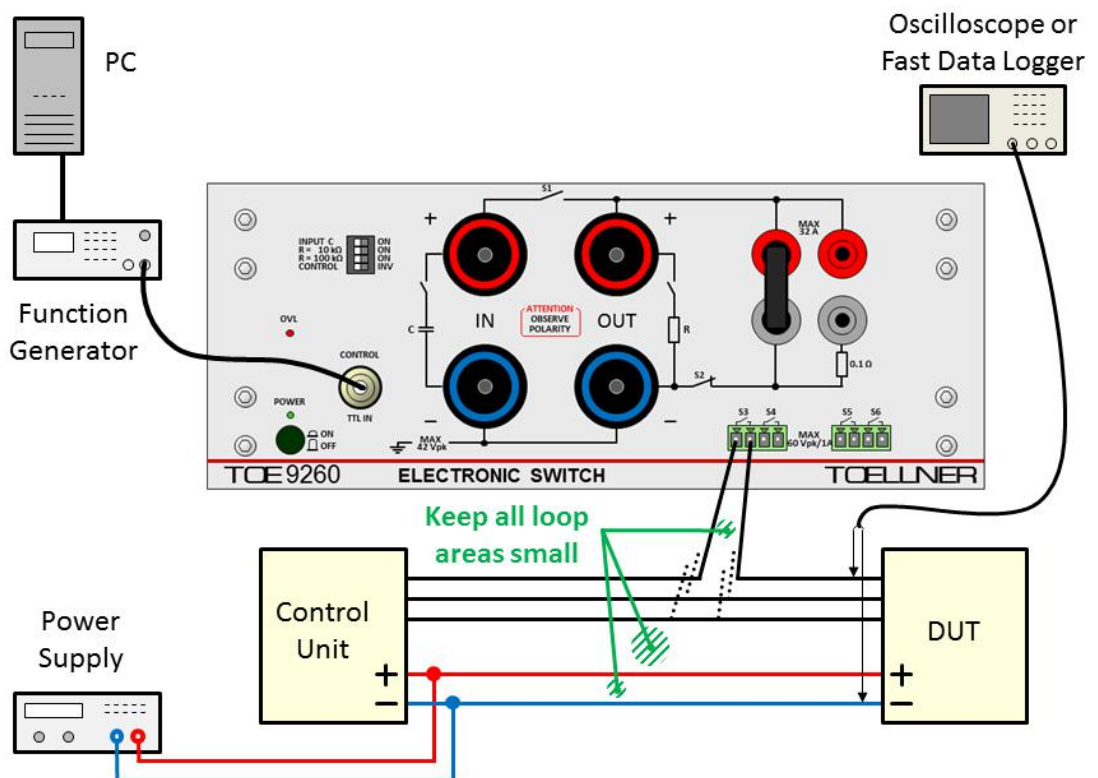

Fig. 2: Test assembly for LV 124, E-13; interruption of a signal pin

2.3.2

E-13, interruption of signal pins – reference measurements

This section applies to LV 124, version 2013 only. That standard requires reference measurements before an interruption test is carried out with the DUT. Such a reference measurement gives proof of the slew rate of the switching operation. For the reference measurements of the E-13 test the DUT is replaced by a reference resistor of $1\ \Omega \pm 5\%$ resp. $1\ \text{k}\Omega \pm 5\%$ of low parasitic inductance.

To avoid the addition of too high cable inductivity, the reference resistor shall be connected close to the signal line switch by closely spaced wires. The switchable reference resistor TOE 9260/104 may be connected to power source and signal line switch by provided suitable cables.

Due to the 1 A current limit of a signal line switch, the measurement with the $1\ \Omega$ resistor shall be carried out at a voltage of 1 V as shown in Fig. 3. Applying such a low voltage level instead of the actual voltage of the signal pin of the control unit has no significant influence on the timing of the measured waveform. Reference measurements with the $1\ \text{k}\Omega$ resistor can be executed with the same voltage as the normal DUT operation voltage.

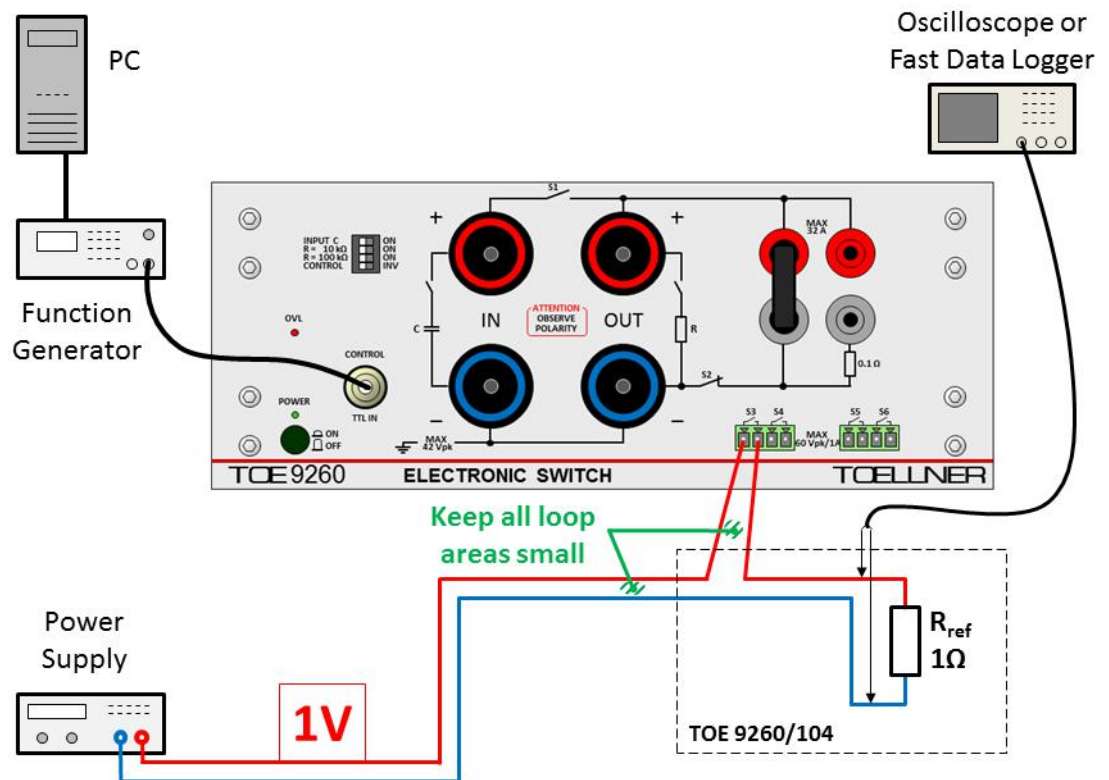

Fig. 3: Measurement with a $1\ \Omega$ reference resistor at a voltage level of 1 V

If the DUT is tested with two paralleled signal line switches (\rightarrow 2.3.1), the reference measurements have to be carried out with the same configuration of paralleled switches. The test voltage for the $1\ \Omega$ reference resistor may be increased up to 2 V.

2.3.3

E-13, interruption of ground pins

Also for the interruption of a ground pin, a signal line switch of the TOE 9260 is used. Such a signal line switch is applicable for a ground current up to 1 A.

If up to 2 A have to be switched, two signal line switches can be paralleled. It is not recommended to operate more than two switches in parallel. With three or four switches in parallel the timing requirements of the LV 124-2013 cannot be fulfilled with a 1 k Ω reference resistor.

Fig. 4 shows the test assembly with use of one of the signal line switches of the TOE 9260.

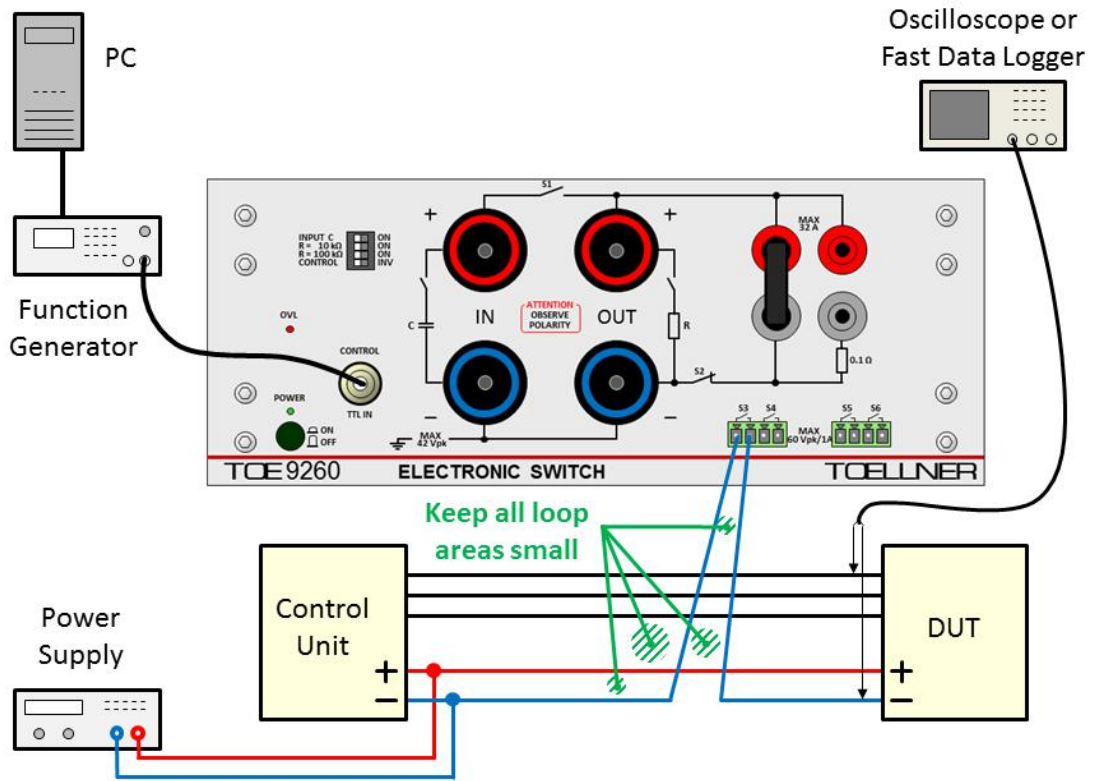

Fig. 4: Test assembly for LV 124, E-13; interruption of a ground pin

2.3.4

E-13, interruption of ground pins – reference measurements

This section applies to LV 124, version 2013 only. That standard requires reference measurements before an interruption test is carried out with the DUT. Such a reference measurement gives proof of the slew rate of the switching operation. For the reference measurements of the E-13 test the DUT is replaced by a reference resistor of 1 $\Omega \pm 5\%$ resp. 1 k $\Omega \pm 5\%$ of low parasitic inductance.

To avoid the addition of too high cable inductivity, the reference resistor shall be connected close to the signal line switch by closely spaced wires. The switchable reference resistor TOE 9260/104 may be connected to power source and signal line switch by provided suitable cables.

Due to the 1 A current limit of a signal line switch, the measurement with the 1 Ω resistor shall be carried out at a voltage of 1 V as shown in Fig. 5. Applying such a low voltage level instead of the actual voltage of the control unit has no significant influence on the timing of the measured waveform. Reference measurements with the 1 k Ω resistor can be executed with the same voltage as the normal DUT operation voltage.

Note If the applied power supply has an internal capacity between its minus terminal and earth, the oscilloscope resp. data logger must not earth the minus terminal of the reference resistor. A differential probe or an isolating transformer for supplying the oscilloscope resp. data logger shall be used in this case. Otherwise a capacity appears across the signal line switch, and the switching timing is slowed down, especially at small load currents as in case of the 1 k Ω reference resistor.

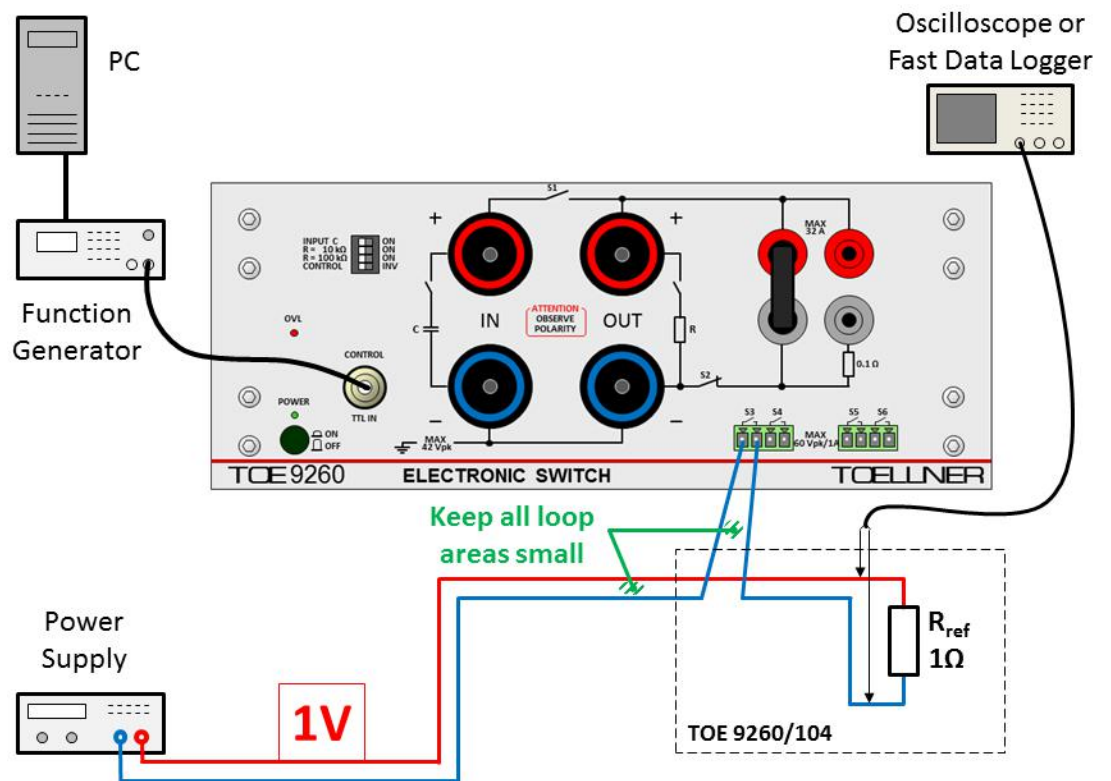

Fig. 5: Measurement with a 1 Ω reference resistor at a voltage level of 1 V

If the DUT is tested with two paralleled signal line switches (→ 2.3.3), the reference measurements have to be carried out with the same configuration of paralleled switches. The test voltage for the 1 Ω reference resistor may be increased up to 2 V.

3. Tests according to standard LV 148

3.1 LV 148, E48-09, Short interruptions

Fig. 6 shows the test assembly for test E48-09. The 19 mm connecting plug must be placed as shown.

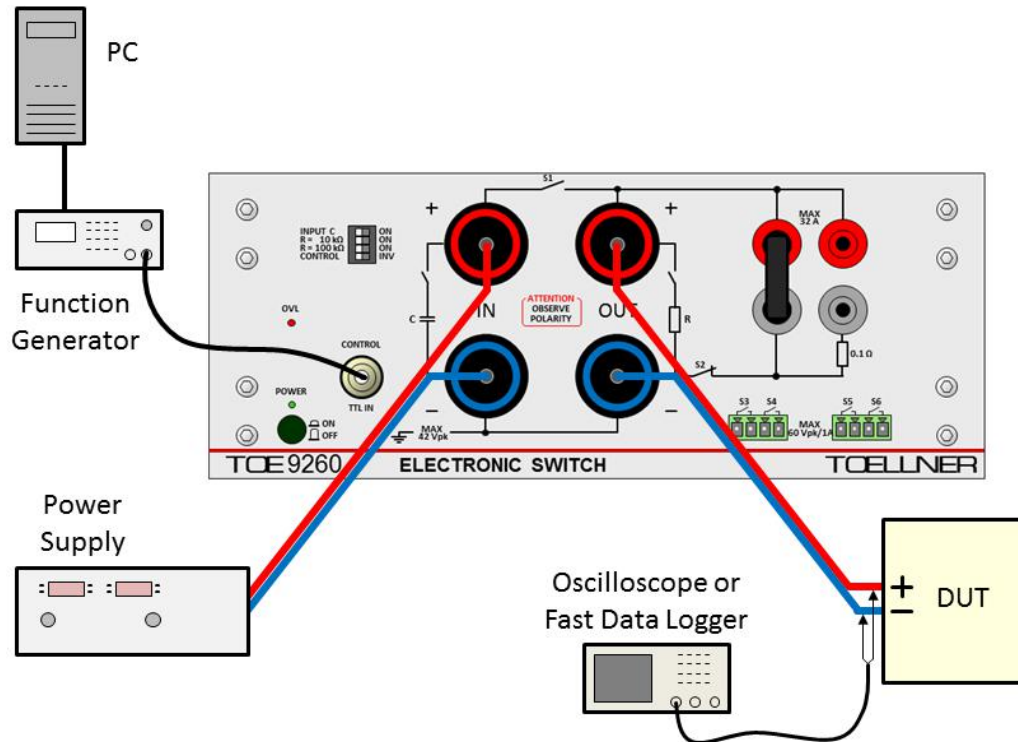

Fig. 6: Test assembly for LV 148, E48-09

Note The important points for test execution in line with the requirements of the standard aim at the wiring as explained in the following:

- The cross section of the cables must fit to the drawn current. For currents up to 100 A please use the cables TOE 9260/22 and TOE 9260/23 (length 0.50 m) resp. TOE 9260/24 and TOE 9260/25 (length 1.20 m).
- The two wires from the power supply to the IN sockets of the TOE 9260 have to be laid as closely spaced as possible (e.g. twisted) to reach minimum inductance values.
- As long as no artificial network is applied between the power supply and the IN sockets of the TOE 9260, the internal capacitor at the input of the TOE 9260 should be activated by setting the DIP switch "INPUT C" to "ON". So the shortest possible rise and fall times of the voltage at the DUT are achieved.
- If an artificial network between the power supply and the IN sockets of the TOE 9260 is necessary, the internal capacitor at the input of the TOE 9260 must be deactivated by setting the DIP switch "INPUT C" to "OFF". In that case the two wires from the artificial network to the IN sockets of the TOE 9260 have to be laid as closely spaced as possible (e.g. twisted) and also kept as short as possible to get short rise and fall times at the DUT.
- Also the two wires from the OUT sockets of the TOE 9260 to the DUT have to be laid as closely spaced as possible (e.g. twisted). Any additional cable inductance will act as an inductive filter together with the resistance and / or capacitance of the DUT, which results in increased rise and fall times measured at the DUT.
- If the DUT has to be connected by a wiring harness or if a wiring harness is part of the DUT, the said remarks are valid for the cables from the OUT sockets of the TOE 9260 to the start point of the wiring harness.